

CoPS: Context Prefetching Handover Scheme on 4G Outdoor Small Cell Testbed

Ping–Jung Hsieh[†], Po–Hung Lin[†], Yu–Chen Lee[†], Rong–Dong Chiu[†], Hung–Yu Wei^{†*} and Wen–Hsin Wei⁺

[†]Department of Electrical Engineering, National Taiwan University, Taipei, Taiwan

⁺Smart Network System Institute, Institute for Information Industry, Taipei, Taiwan

Corresponding Author*: hywei@ntu.edu.tw

Abstract—Mobility enhancements of small–cell networks in the IEEE/3GPP standard meeting is an important issue, where the mobility robustness is aimed at the prevention and solution of connection failure/exceptions that occur as a result of uncertain channel condition or aggressive mobility. Although exception handling, such as uncontrolled handover and connection re–establishment, is supported in a 4G wireless network system, it still results in a lengthy yet acceptable handover duration. Notably, the results from commercial 4G cellular systems show that the preparation phase period accounting for 19% of the controlled handover duration is long and prone to uncompleted handover.

In this work, we propose a Context Prefetching handover Scheme (CoPS) for 4G broadband wireless access networks in order to effectively reduce the lengthy preparation phase period in the controlled handover procedure without any modifications on user side. We also propose two triggering mechanisms according to the mobility scenario for a trade–off between the overhead and the benefit of prefetching. We implement CoPS and the triggering mechanisms on a WiMAX small–cell network platform of outdoor small cell base–stations. Our field trial results show significant improvements of CoPS in a reduction of the preparation phase period by 78% as well as a reduction of handover duration by 17% and in negligible resource occupation overhead. The proposed solutions also can be introduced into existing LTE infrastructures.

I. INTRODUCTION

As the number of hand–held devices in use (e.g., smart phones, tablets) has grown exponentially over the last few years, more users require access to services from broadband wireless networks on the go. Therefore the technical support for maintaining robust connections to mobile users in the wireless network system is essential. According to the Cisco Visual Networking Index [1], the amount of data consumption of mobile applications is increasing rapidly and the top three application types are video/communication applications (e.g., YouTube and Netflix), information applications (e.g., Google Maps and News), and social networking applications (e.g., Facebook and Twitter). These applications require smooth data transmission, rapid active time, and real–time update to satisfy the demands of the user experience. Hence, robust and seamless mobility are proposed as objectives for the IEEE/3GPP standard meeting to address the requirements [2].

Recently, popular WiFi systems cannot meet satisfactory mobility requirements due to small coverage and authentication delays. In contrast to WiFi LAN technology, 3G cellular networks such as CDMA and UMTS are a type of wire–area

wireless access network, and provide more robust mobility than WiFi. However, 3G cellular networks do not account for seamless mobility due to limitations in the MAC and PHY design. There is a potential technology, 4G, emerging to dethrone WiFi and 3G networks. This forms the basis of our attention.

The 4G cellular networks, such as WiMAX [3] and LTE [4], are deployed in order to reduce delay in terms of connection, transmission and handover latency, increase user data rate, extend coverage, improve system capacity, and support seamless mobility, etc. Further, small cells [5] formed by low–power wireless access point are also proposed in 4G technologies to provide additional capacity and ease the pressure caused by the dense users or high demand for mobile traffic in some parts of the area of a macro cell.

Of these objectives, reduced handover delay and seamless mobility can be achieved by standardized techniques of controlled handover, mobility robustness and handover techniques such as hard and soft handover. These techniques have studied and are currently being improved in the standard meetings. To improve seamless mobility in a 4G cellular network, context retrieval and data path/bearer pre–establishment of the mobile device are conducted in the preparation phase as the first half within the entire handover procedure before a handover action is executed. Through the preparation phase, the period of the handover action phase can be reduced by procedure handling in advance. However, if channel condition is getting worse rapidly or the node speed is aggressive (even further critical in small–cell networks), one kind of failure/exception is caused by switching too–early which means that a user node begins attaching to a target base–station before the preparation phase is completed.

Although a 4G wireless network system supports exception handling for mobility robustness, which aims at preventing and solving connection failures that occur as a result of mobility, it still results in lengthy handover duration when a handover is triggered by a user node in a bad channel condition and the user node attaches to a new base–station successfully. If the preparation phase fails and triggers the exception handling such as an uncontrolled handover and connection re–establishment, some uncompleted procedures in the preparation phase should be finished in the pending handover action phase, and the result is still faster than the network entry procedure. Notably, the results from commercial

4G picocell systems [6] show that the preparation phase period accounting for 19% of the controlled handover duration is prone to uncompleted handover.

In this work, we propose a Context Prefetching handover Scheme (CoPS) for 4G cellular networks to focus on reeducation in the overlong preparation phase period in the entire handover procedure with compatibility and simplicity. Thus the shorter period of preparation phase, the smaller probability of occurrence of uncompleted handover. The CoPS scheme enables the serving base-station and potential target base-stations to do the procedures in the preparation phase before the controlled handover procedure. Therefore, the prefetched procedures accelerate the preparation phase as well as the handover procedure. Intuitively, an overhead in the prefetching scheme is on resource occupation. It is related to the time spent in the duration between the serving base-station initiating the context prefetching and a mobile device starting the handover procedure. Hence, we also propose two base-station-initiated triggering mechanisms according to the mobility scenario for a trade-off between the overhead and the benefit of prefetching.

We implement CoPS and the triggering mechanisms on PicoChip [7] WiMAX pico base-stations with protocol stack software and its modification supported by the Institute of Information Industry (III) [8]. However, using LTE platforms is too costly to adopt. The proposed solutions can still be introduced into existing LTE systems. The WiMAX small-cell network testbed consists of two outdoor WiMAX pico base-stations (BSs), two pairs of an indoor unit (IDU) and an outdoor unit (ODU), an Access Service Network Gateway (ASN-GW), a WiMAX mobile station (MS) and a PC to monitor. The testbed we implement our scheme with supports Hard Handover (HHO) only. All of the implementations are on the BS only and no modification is required on the client or the gateway of the network. In this manner, commercial clients are compatible with our testbed or any WiMAX cellular system. CoPS is completely applicable to legacy MSs. We conduct the field trial in an outdoor experimental environment and evaluate the performance of CoPS and the trigger mechanisms compared with the controlled handover procedure based on the IEEE 802.16e standard.

This paper indicates the following contributions:

- We propose CoPS, which is a prefetching-based MAC layer handover scheme for 4G cellular networks, and conduct field trials to test its performance.
- We implement two triggering mechanisms to be applied in different mobility scenarios with negligible overhead to initiate CoPS.
- CoPS reduces the total handover period by approximately 17% according to our field trial results. The field trial consists of two outdoor small cells (WiMAX pico BSs). Specifically, we reduce the *Preparation Phase* of the controlled handover by approximately 78% of the total preparation time.
- CoPS is implemented on the BS only and no modification is required on the client-side or the gateway of the network. In this manner, commercial/legacy clients are

compatible with our or any WiMAX BS.

The rest of the paper is organized as follows. We introduce the related work on handover issues in Section II. Section III introduces the controlled and uncontrolled handover schemes in mobile WiMAX networks. Section IV introduces CoPS and two triggering mechanisms. Section V introduces the field trial settings. Section VI compares the handover performance and the overhead of different triggering mechanisms. Section VII indicates lessons learned for discussion. In Section VIII we conclude this paper.

II. RELATED WORK

Handover Issues in WiMAX Cellular Networks: Handover issues for the MAC layer, network layer, and cross-layer scenarios along with some probable research directions and solutions are discussed in [9]. In [10], the authors designed and implemented a C-RAN testbed with a flexible backhaul architecture, which supports fractional frequency reuse (FFR) and a distributed antenna system (DAS) to cater for heterogeneous users (static and mobile MSs). In DAS mode, the same radio signal is transmitted to multiple small cells to provide increased coverage and avoid frequent handovers in small cells. In [11], the authors deployed the WiMAX testbed; the network layer MIPv6 handover performance was evaluated and discussed. Our proposed CoPS focuses on the MAC layer handover design and also takes the handover robustness into consideration. To the best of our knowledge, no prior work has implemented a handover mechanism on the MAC layer of the WiMAX testbed and tested the handover performance in field trial.

Predictive Prefetching in Networks: In [12], the author used the mobility model which considers the user's moving speed and direction to propose the prefetching zone which can fetch information in advance, but with limited information available. It has been claimed that people often drive on familiar routes in their daily lives, so the mobility and connectivity related information can be predicted by using historical information in the vehicular WiFi networks [13]. Prediction of the vehicles mobility means it is possible to prefetch data directly from the AP instead of connecting to a server on the Internet as soon as the vehicle approaches and connects with an AP. In [14], the authors propose a Prefetching-based Fast Handover procedure in the LTE network. The mechanism aims to prefetch higher layer data to nearby femtocells in the proximity of the UE to reduce the time of signaling and data exchange between the femtocells and the Mobile Core Network (MCN) during the actual handover. However, CoPS enables the BS to prefetch data at the backhaul, and does not require modification at the client-side or the air interface. In addition it also has minimum control overhead. We consider the resource overhead incurred by the prefetching-based solutions.

III. BACKGROUND

There are two types of handover: controlled and uncontrolled in a mobile WiMAX network [15].

A. Controlled Handover

Fig. 1 shows a WiMAX handover message flow diagram for typical controlled handover. The WiMAX handover involves R1/R6-related messages, where R1 is the reference point consisting of the protocols and procedures between the MS and the BS, and R6 is the reference point consisting of the set of control and data path protocols for communication between the BS and the ASN-GW within a single ASN. In this figure, we list a single target BS for example, however, it could be many neighbor BSs around the MS. The handover duration can be divided into three phases, *Network Topology Acquisition Phase* (NTAP), *Preparation Phase*, and *Action Phase*.

In the *Network Topology Acquisition Phase*, the BS periodically broadcasts the Mobile Neighbor Advertisements (*MOB_NBR-ADV*) to notify the MS of both the physical and link layer information of the neighboring BSs such that the MS can get the neighboring BSs list in a *MOB_NBR-ADV*. After the downlink signal strength between the MS and the serving BS drops below a preconfigured scan threshold, the MS sends a *MOB_SCN-REQ* to the serving BS and the serving BS responds with a *MOB_SCN-RSP* to allocate a scanning duration. The MS then begins the ranging procedure with those neighboring BSs for the uplink synchronization and parameter (e.g., transmission power) adjustment.

In the *Preparation Phase*, when the downlink signal strength between the MS and the serving BS drops further than the configured handover threshold, the MS sends out a *MOB_MSHO-REQ* including one or more potential target BSs to the serving BS to notify that the channel condition is bad and the MS wants to handover to another BS. After receiving the *MOB_MSHO-REQ*, the serving BS sends a *HO_Req* to the potential target BSs in the *MOB_MSHO-REQ*. The target BS which receives the *HO_Req* then requests the AK context for the MS by initiating a *Context Retrieval* procedure with ASN-GW. Furthermore, the target BS initiates a *Data Path Pre-Registration* procedure for the MS with ASN-GW. After finishing the *Context Retrieval* and the *Data Path Pre-Registration* procedures, the target BS will return a *HO_Rsp* to the serving BS. The serving BS then transmits a *MOB_BSHO-RSP* to the MS containing one or more potential target BSs information. At the same time, the serving BS sends a *HO_Ack* to those potential target BSs as a response for receiving the *HO_Rsp*.

In the *Action Phase*, the MS sends a *MOB_HO-IND* to the serving BS to initiate a handover to the target BS. The MS also terminates its connection with the current serving BS at this time. Upon receiving the *MOB_HO-IND*, the serving BS sends a *HO_Cnf* to the selected target BS to notify it that there is an impending handover of the MS. The target BS then sends back a *HO_Ack* to the serving BS. And the MS will initiate a *Network Re-Entry* procedure with the target BS. After initiating the *Data Path Registration* procedure with ASN-GW, the target BS will send a *HO_Complete* to the serving BS through ASN-GW to notify the completion of the handover. The serving BS then returns a *HO_Ack* to the target

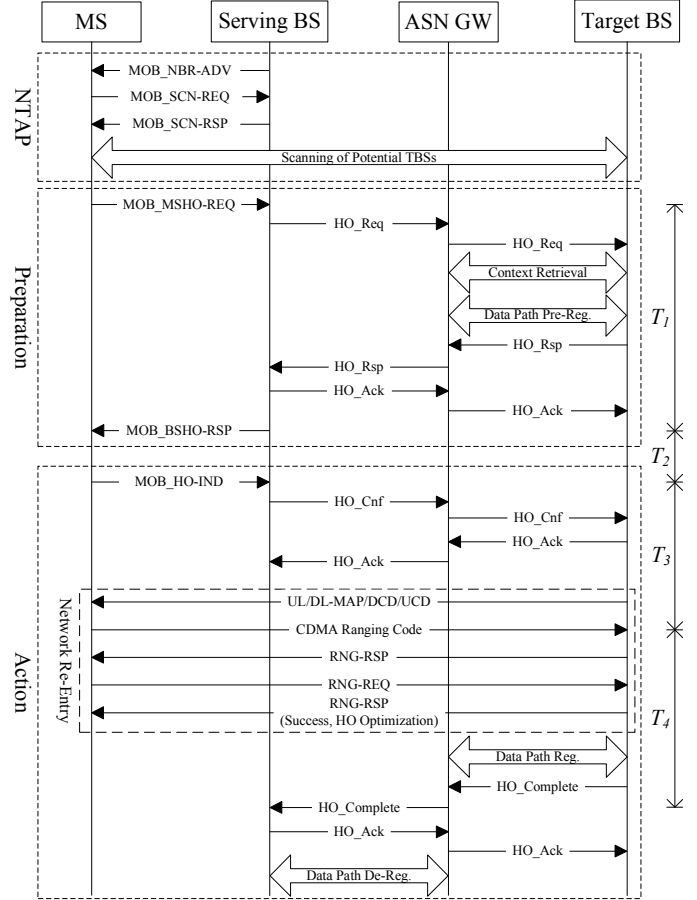

Fig. 1. Controlled Handover Message Flow

BS. After the serving BS receives the *HO_Complete*, it will initiate the *Data Path De-Registration* procedure with ASN-GW to release the context of the MS.

B. Uncontrolled Handover

If the MS begins ranging at the target BS when the *Preparation Phase* has not been completed or is interrupted, an uncontrolled handover will occur [16]. The serving and target BSs are still doing the handover steps in the middle of the *Preparation Phase*, if the MS moves too fast. In this case it will become an uncontrolled handover and deteriorate the handover performance.

IV. PROPOSED HANDOVER SCHEME

A. Context Prefetching Handover Scheme (CoPS)

To alleviate the worse conditions of uncontrolled handover, we need to reduce the execution time of the *Preparation Phase*. Therefore, we propose a prefetching-based solution, CoPS, to speed up the *Preparation Phase* by prefetching the MS context and data path in advance of the *Preparation Phase*. The primary modification of the preparation procedure is shown in Fig. 2. We split the *Preparation Phase* of the controlled handover into two phases, the *Prefetching Phase*, and the *Preparation Phase*. The *Action Phase* is the same as the controlled handover.

The serving BS initiates the *Prefetching Phase* of CoPS by sending the *HO_Req* to the neighbor BSs (potential target BSs). After receiving the *HO_Req*, the neighbor BSs request AK context for the MS by initiating the *Context Retrieval* and the *Data Path Pre-Registration* procedures with ASN-GW as the controlled handover. The context of the MS persists on the potential target BSs, which will send the *HO_Rsp* to the serving BS. When the serving BS receives the *HO_Rsp*, it will not send the *MOB_BSHO-RSP* to the MS immediately, which is different from the *Preparation Phase* in the controlled handover.

In the *Preparation Phase* of CoPS, when the downlink signal strength of MS drops below the handover threshold as in the controlled handover, MS sends the *MOB_MSHO-REQ* for a handover to another BS. Since the serving BS has already done the *Context Retrieval* and *Data Path Pre-Registration* procedures, the serving BS can respond with *MOB_BSHO-RSP* to MS immediately without wasting time during *Context Retrieval* and *Data Path Pre-Registration* procedures. In short, the new preparation phase is modified to include only the signaling exchange of *MOB_MSHO-REQ* and *MOB_BSHO-RSP*. Other procedures in the original preparation phase are finished in the *Prefetching Phase*. Therefore, after the MS enters a preparation phase (the BS receives *MOB_MSHO-REQ*) the waiting time for the end of the preparation phase (the BS sends *MOB_BSHO-RSP*) can be effectively reduced.

A special case for compatibility should be considered in CoPS. The *Prefetching Phase* is not complete when the MS sends the *MOB_MSHO-REQ*. This exception would occur due to rapid decrease of the downlink signal strength of the MS. To handle this exception, CoPS includes a fallback function, where the serving BS would wait to send the *MOB_BSHO-RSP* until the *Prefetching Phase* is completed after receiving the *MOB_MSHO-REQ*.

Moreover, the handover procedure in LTE cellular networks consists of the preparation, execution, and competition phases, which are similar to WiMAX cellular networks. As a result, CoPS is applicable to LTE.

B. Different Triggering Mechanisms

1) *Periodic Triggering Mechanism*: We enable the serving BS to periodically send the *HO-REQ* to the neighboring BSs (potential target BSs) to complete the *Context Retrieval* and the *Data Path Pre-Registration* procedures in the *Prefetching Phase*. The context of the MS persists on the BSs for a period. After the end of the period, the BSs restart the prefetching procedure periodically for ensuring the BSs prefetched all the time. However, the MS does not carry out handovers for the majority of the time, which may mean that the resource occupation of the CPU loading and the wired channel resource of the backhaul (R6) are wasted. The advantage of the periodic triggering mechanism is to ensure that the serving BS and the neighbor BSs have done the prefetching procedure before the MS sends the *MOB_MSHO-REQ* to the serving BS.

2) *Signal-Based Threshold-Triggered Mechanism*: The serving BS can refer to the channel condition of the MS by

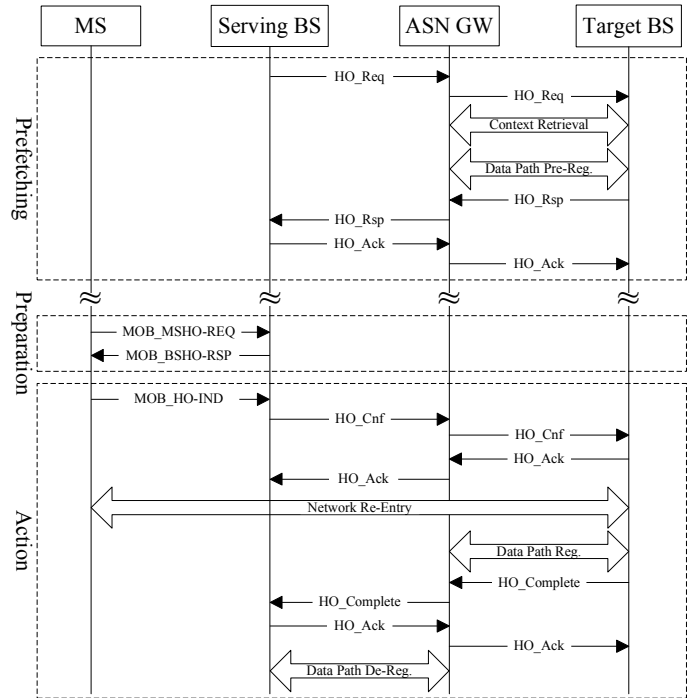

Fig. 2. CoPS Message Flow

receiving the Channel Quality Information Channel (CQICH) report from the MS or by receiving the *REP-RSP* sent by the MS for responding to the *REP-REQ* which is sent by the serving BS. From the CQICH report, the serving BS can obtain the downlink Carrier to Interference-plus-Noise Ratio (CINR) of the MS. From the *REP-RSP*, the serving BS can obtain both the downlink CINR and the downlink Received Signal Strength Indicator (RSSI) of the MS. The idea is that the index of downlink CINR/RSSI is used by the serving BS to compare with the prefetching threshold, which we design for triggering the *Prefetching Phase*. If the index drops below the threshold, the serving BS initiates the *Prefetching Phase*. The advantage of the signal-based threshold-triggered mechanism is not only reducing the resource occupation of the CPU load but also the wastage of the wired channel resource of the backhaul compared with the periodic triggering mechanism.

However, the serving and the neighbor BSs may still do the prefetching procedure in vain for both triggering mechanisms since the MS could not handover after all. This results in overhead of the BS and wastage of the backhaul. According to our field trial results, our proposed triggering mechanisms have a lower CPU load. In relation to the wastage of wired channel resources, the size of the total packets in the *Prefetching Phase* is approximately 3.4 Kbytes. Most of the backhauls now have more than 100 Mbps bandwidth; the wastage of the wired channel is negligible.

V. FIELD TRIAL SETTING

In this section, we divide the experiment into two parts, outdoor pico BS implementation and our testbed of the WiMAX small-cell network.

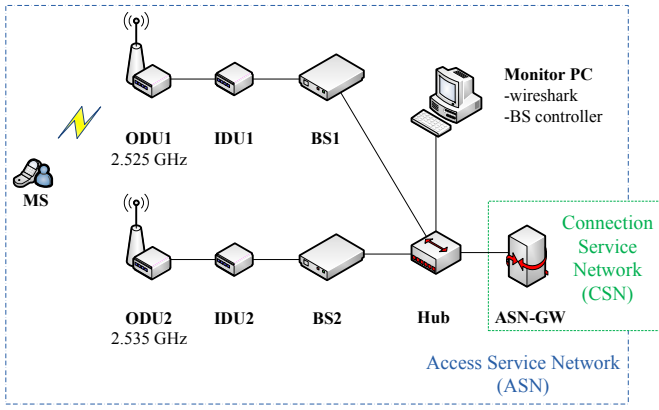

Fig. 3. Mobile WiMAX Testbed

TABLE I
MOBILE WiMAX PICO BS PARAMETERS

Parameters	Values
Operating frequency	2.525/2.535 GHz
Bandwidth	10 MHz
Frame length	5 ms
FFT size	1024
Transmission Power	18 dBm
Scan Threshold (θ_s)	-45 dBm (RSSI)
Handover Threshold (θ_{ho})	-55 dBm (RSSI)
Prefetching Threshold (θ_{pf})	-45 dBm (RSSI)

A. Outdoor Pico BS Implementation

All of our implementations are on the picocell WiMAX BSs only, where we significantly extend and modify the R1 and R6 handover modules for CoPS and the report module for the triggering mechanisms. The modifications result in approximately 1000 lines of C code. CoPS is implemented into the state machine of the R6 handover module. The custom-made intermediate signaling message, prefetching event, is added to the R1 handover module to notify the R6 handover module of initiating the *Prefetching Phase*. The triggering mechanisms are implemented in the report module to refer to the index of the channel condition in the CQICH report or *REP-RSP* and trigger the prefetching event notification in the R1 handover module.

B. WiMAX Small-Cell Network Testbed

Our WiMAX small-cell network testbed for our implementation consists of two outdoor pico WiMAX BSs, two pairs of an IDU and an ODU, an ASN-GW, a WiMAX MS, and a monitor PC as depicted in Fig. 3. The specification of the mobile WiMAX BS is based on the IEEE 802.16e. The mobile WiMAX BS parameters are listed in Table I. Our WiMAX small-cell testbed can be divided into two parts, ASN and Connectivity Service Network (CSN). In the ASN, there are the WiMAX BSs and the ASN-GW. The ASN-GW controls and aggregates the traffic from numerous WiMAX pico BSs and creates the data path connecting the MS and the CSN. The CSN is used to provide control and management functions such as Dynamic Host Configuration Protocol (DHCP), and the Authentication, Authorization, and Accounting (AAA) server. In our WiMAX testbed, the CSN is implemented on the same computer as the ASN-GW. The ODU is mounted

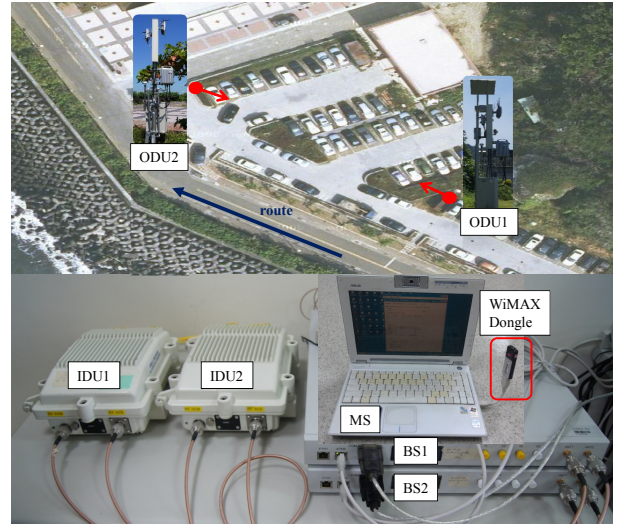

Fig. 4. Mobile WiMAX Field Testbed

with a directional antenna and is connected with the IDU through an intermediate frequency (IF) cable. The monitor PC is connected to the hub which is also connected with the BSs and the ASN-GW. We can modify the settings of the BS and monitor the packets between the BS and the ASN-GW through the monitor PC. The Customer-Premises Equipment (CPE) we used for the MS is a dongle made by GCT chip [17].

As shown in Fig. 4, our WiMAX small-cell network testbed is deployed in an outdoor experimental environment. ODU1 and ODU2 are in a parking lot and their antenna directions (red arrows) are opposite each other. The other equipment e.g., the BSs, the IDUs, the ASN-GW and the monitor PC are set up in an indoor laboratory. This scenario of the testbed could be a surveillance system to monitor what happens in the parking lot or on the road adjacent to the parking lot. Therefore, we conduct the field trial of handover under this scenario. We use the ping command on the MS to probe the ASN-GW in order to maintain an active connection between a MS and a BS during the handover procedure.

VI. FIELD TRIAL RESULTS

A. Handover Period

Method: To get an insight into the comparison of handover duration between the controlled handover and CoPS, we define four time periods as shown in the figure, which are T_1 , T_2 , T_3 , and T_4 . T_1 is from *MOB_MSHO-REQ* to *MOB_BSHO-RSP*. T_2 is from *MOB_BSHO-RSP* to *MOB_HO-IND*. T_3 is from *MOB_HO-IND* to the *CDMA Ranging Code*. T_4 is from the *CDMA Ranging Code* to *HO_Complete*.

We use the Wireshark installed on the monitor PC to capture the packets passed through the hub which is at R6 between the BSs and the ASN-GW. The R1 packets will be sent to the ASN-GW by the BS, which is a special debug function of the BS supported by the implementation of III. In this manner, we can log all the R1 and the R6 packets. We repeat the experiments (routes) 20 times to present an average results in order to reduce the impact of minor anomalies.

TABLE II
HANDOVER PERIODS

	T_1 (s)	T_2 (s)	T_3 (s)	T_4 (s)	T_{ho} (s)
GCT/Controlled	0.042	0.059	0.070	0.050	0.221
GCT/Proposed	0.009	0.056	0.069	0.049	0.183

There is no specific mobility model, and the MS moves along the route (the blue arrow illustrated in Fig. 4) until the handover to the BS2 occurs. The average velocity of the MS is approximately 15km/h due to speed restriction in the environment. The triggering method we use in this experiment is a periodic triggering mechanism to ensure that the BS does the *Prefetching Phase* before handover, and its period length is configured as 15 s. Furthermore, the same results of the reduction in the preparation phase period are conducted by both periodic and threshold triggering mechanisms. Different triggering mechanisms do not affect the period of the handover of CoPS. In this experiment, we set both θ_s and θ_{pf} as -45 dBm, and θ_{ho} as -55 dBm according to the user experience in the field trial environment.

Results: We show the average time of T_1 , T_2 , T_3 , T_4 , and the handover duration, T_{ho} , which is equal to the sum of T_1 , T_2 , T_3 , and T_4 . As shown in Table II, the average time of the *Preparation Phase*, T_1 , is from 0.042 s to 0.009 s and the reduction ratio is 78%. T_{ho} is reduced from 0.221 s to 0.183 s and the reduction ratio is 17%. Since CoPS implements the *Context Retrieval* and *Data Path Pre-Registration* procedures in advance, the serving BS immediately responds with *MOB_BSHO-RSP* to MS, which is suffering from worse channel conditions, when receiving *MOB_MSHO-REQ*.

B. Overhead Comparison

Method: To determine the overhead of the two triggering mechanisms and the controlled handover, we monitor the CPU load of the process *wbsctrl* which handles the operations at R6. Over the duration of the monitoring interval the MS did not handover (let the downlink RSSI of MS be higher than T_{ho} but lower than T_{pf}) because we focused on the overhead incurred by the prefetching-based solution. To obtain the CPU load test with finer granularity, we log the percentage of the CPU usage for the process *wbsctrl* every second with one MS connecting to the serving BS for 30 minutes without doing handover. This configuration significantly simplifies the description and provides better demonstration. Moreover, we consider various channel conditions, which are two cases of good and bad channel conditions, for the overhead of the signal-based threshold-triggered mechanism. The good and bad channel conditions are represented by an RSSI at the MS of approximately -40 dBm and -50 dBm respectively.

Results: As we can see in Fig. 5(a), the controlled handover does not cause any overhead since there is no action in advance of the handover. Fig. 5(b) shows the frequency of occurrence of the CPU load, which is high, with the average CPU load of the periodic triggering approximately 0.1%. Although the majority of the CPU load is lower than 1%, the periodic triggering mechanism causes persistent prefetching and a higher CPU load cost. As shown in Fig. 5(c), the serving

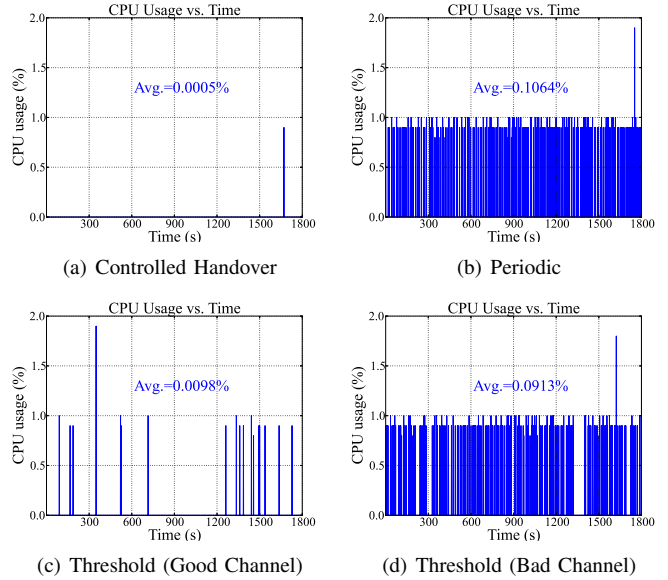

Fig. 5. CPU loading of different triggering mechanisms

BS rarely does the prefetching such that the average CPU load is very low in the good channel condition. In contrast, in Fig. 5(d), the average CPU load for the signal-based threshold-triggered mechanism is about 0.09% in the bad channel condition, which is almost the same as the periodic triggering due to the BS prefetching continuously. The reason for this is that the signal-based threshold-triggered mechanism depends on the channel condition to operate CoPS. Therefore, if we wish to ensure that the BS has done the prefetching steps before the handover, the periodic triggering mechanism is recommended, and it is appropriate for small cells networks and a fixed trajectory scenario. The signal-based threshold-triggered mechanism can cater to heterogeneous users (clients with various speeds) and a dynamic trajectory scenario to initiate CoPS adaptively according to the channel condition, thus alleviating the CPU load.

VII. DISCUSSION

After the observations and the experience in this study, we summarize the following lessons learned:

- The backward compatibility is a key norm in the implementation study. Therefore, a simpler mechanism is better, and a network-controlled mechanism is a trend which centralizes most of controls and provides enhancements from the center without modification on clients.
- In WiMAX/LTE networks, the preparation phase period accounts for almost 19% of the controlled handover duration. It is overlong to cause failures during handover period, even further easily in small-cell networks/high-mobility scenarios. It means that the reductions in the preparation and action phase are important equally.
- Prefetching is a simple concept and works well in the mobility studies, but its configuration is a key role to suit different mobility scenarios with the better performance.

These perspectives can be further extended to the design and the analysis of other complicated networks, e.g., heterogeneous networks.

VIII. CONCLUSION

In this paper, we not only propose CoPS for 4G cellular networks but implement it on a WiMAX small-cell network testbed with compatible modifications. We enable the pico WiMAX BSs and the ASN-GW to do the *Context Retrieval* and *Data Path Pre-Registration* procedures before the actual handover happens. We also implement two triggering mechanisms suitable for the different mobility scenarios with negligible overhead in order to initiate CoPS. In our field trial results, we reduce the total handover period by approximately 17% of the total handover time. Specifically, we reduce the *Preparation Phase* by approximately 78% of the handover preparation time. CoPS is also applicable to commercial/legacy MSs. However, there is still a significant amount of work to study on the WiMAX testbed in the future. The heterogeneous users scenario is a special case worthy of study, which involves the problems of load balancing and resource allocation.

ACKNOWLEDGMENT

This work was supported by the Ministry of Economic Affairs (MoEA) of Taiwan under Grants 102-EC-17-A-03-S1-214.

REFERENCES

- [1] Cisco Visual Networking Index. Global Mobile Data Traffic Forecast Update, 2012-2017. In *Cisco white paper*, 2013.
- [2] 3GPP TS 32.521 version 11.1.0 (2012-12). Self-Organizing Networks (SON) Policy Network Resource Model (NRM) Integration Reference Point (IRP): Requirements. *3GPP Technical Specification*.
- [3] IEEE Standard for Local and Metropolitan Area Networks Part 16: Air Interface for Fixed and Mobile Broadband Wireless Access Systems. *IEEE 802.16e standard*, 2006.
- [4] 3GPP LTE. <http://www.3gpp.org/LTE>.
- [5] 3GPP TR 36.932 version 12.1.0 (2013-03). Scenarios and requirements for small cell enhancements for E-UTRA and E-UTRAN. *3GPP Technical Report*.
- [6] Gemtek femtocell solution. <http://www.gemtek.com.tw/>.
- [7] PicoChip femtocell solution. <http://www.picochip.com/>.
- [8] Institute for Information Industry. <http://web.iii.org.tw/>.
- [9] S.K. Ray, K. Pawlikowski, and H. Sirisena. Handover in mobile wimax networks: The state of art and research issues. In *IEEE Communications Surveys Tutorials*, pages 376–399, 2010.
- [10] C. Liu, K. Sundaresan, M. Jiang, S. Rangarajan, and G. Chang. The Case for Re-Configurable Backhaul in Cloud-RAN based Small Cell Networks. In *Proceedings of the IEEE INFOCOM*, pages 1124–1132, 2013.
- [11] J. Pinola and K. Pentikousis. IPTV over WiMAX with MIPv6 Handovers. In *Proceedings of the IEEE VTC Spring*, pages 1–5, 2009.
- [12] G. Cho. Using Predictive Prefetching to Improve Location Awareness of Mobile Information Service. In *Springer Lecture Notes in Computer Science*, pages 1128–1136, 2002.
- [13] P. Deshpande, A. Kashyap, C. Sung, and Samir R. Das. Predictive Methods for Improved Vehicular WiFi Access. In *Proceedings of the ACM MobiSys*, pages 263–276, 2009.
- [14] A. Rath and S. Panwar. Fast Handover in Cellular Networks with Femtocells. In *Proceedings of the IEEE ICC*, pages 2752–2757, 2012.
- [15] Network Architecture – Stage 2 : Architecture Tenets, Reference Model and Reference Points. *WMF-T32-001-R016v01, WiMAX Forum*, 2010.
- [16] Network Architecture – Stage 3 : Detailed Protocols and Procedures. *WMF-T33-001-R016v01, WiMAX Forum*, 2010.
- [17] GCT. <http://www.gctsemi.com/>.